

Hiru N Patel Supersonic Wind Tunnel

Imperial College London, London

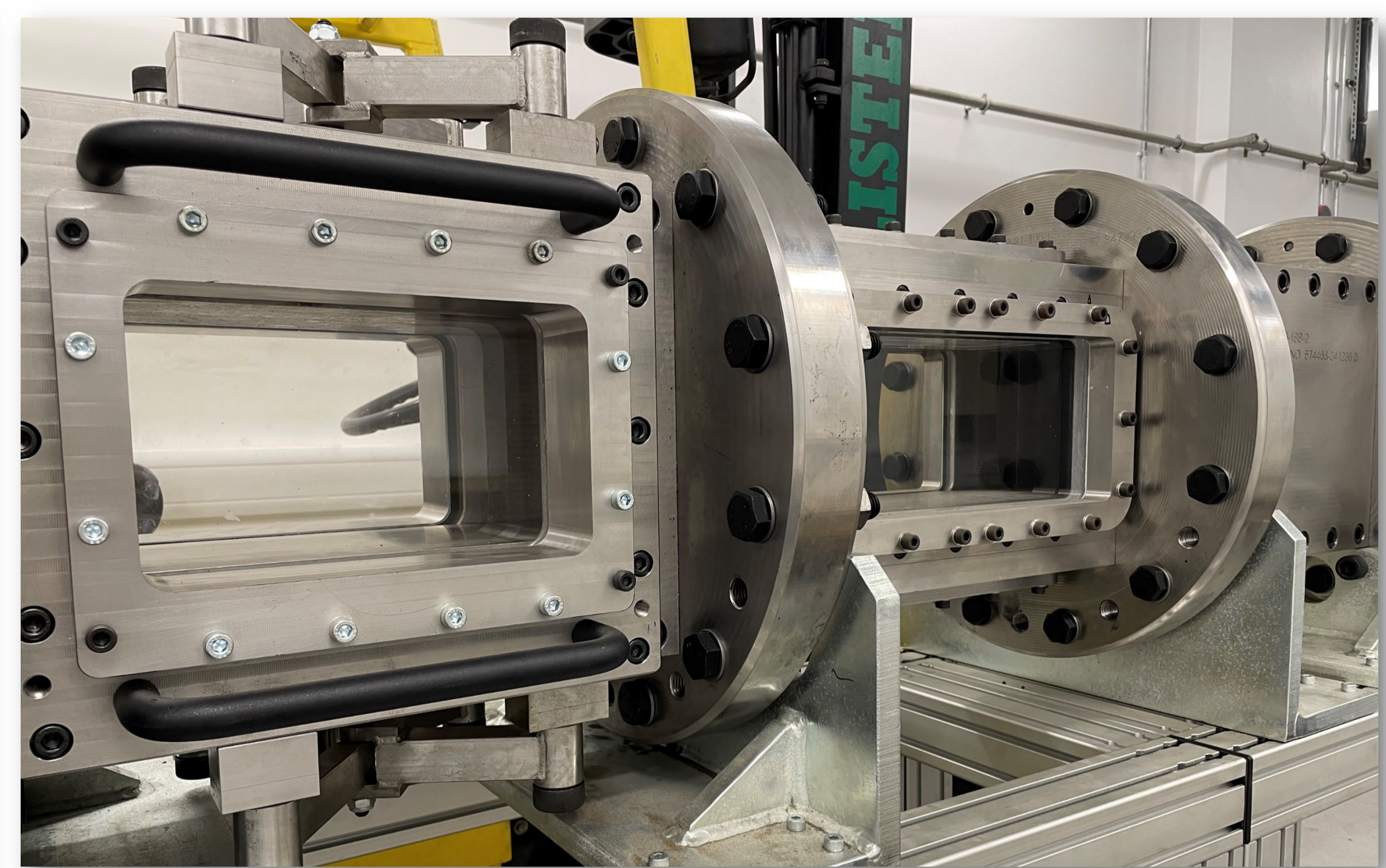

Dr Paul Bruce
Dept. of Aeronautics.
p.bruce@imperial.ac.uk

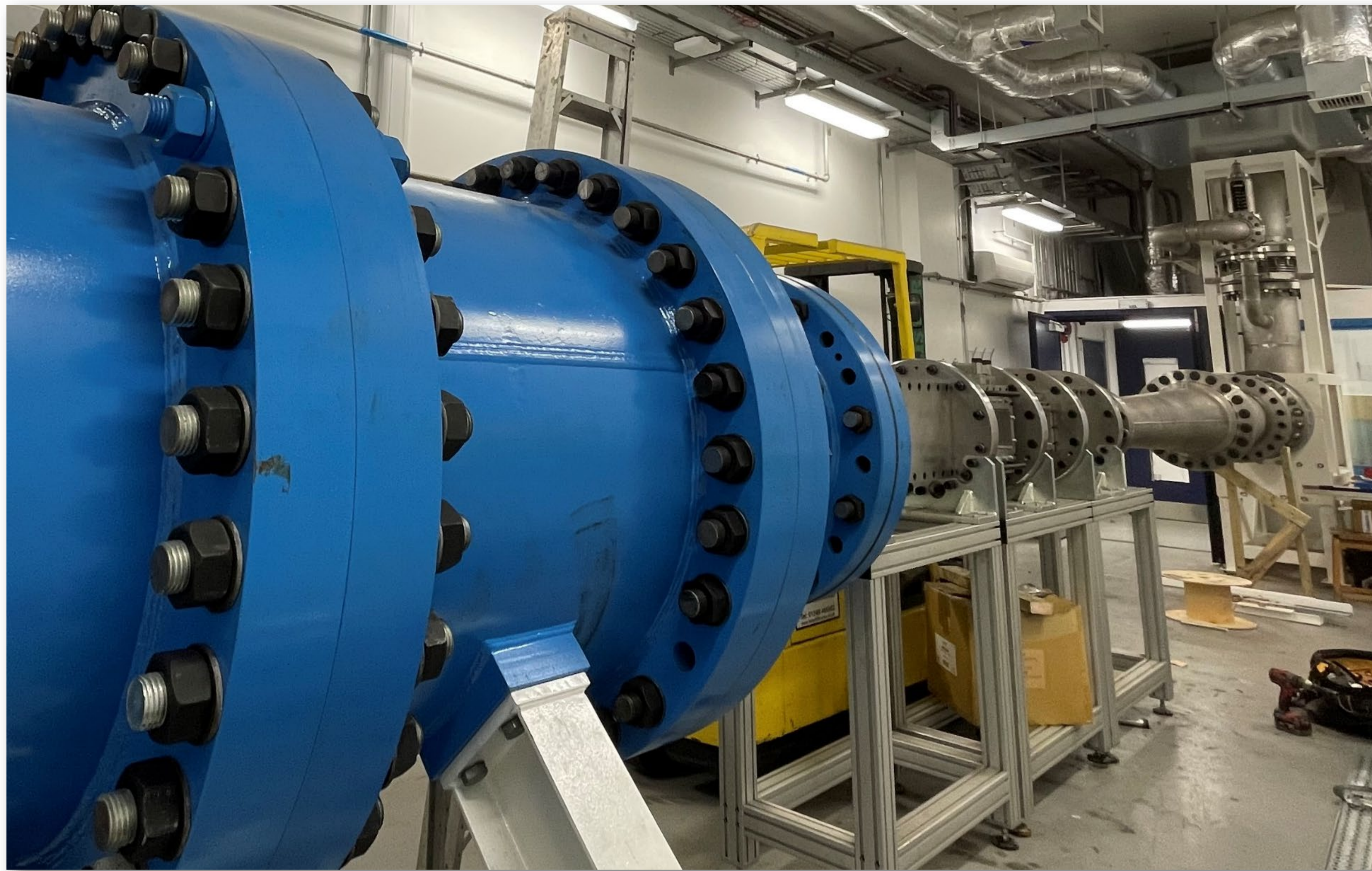

Modular test section with optical access

High-pressure tank

Vacuum chamber

150 x 150 mm test section

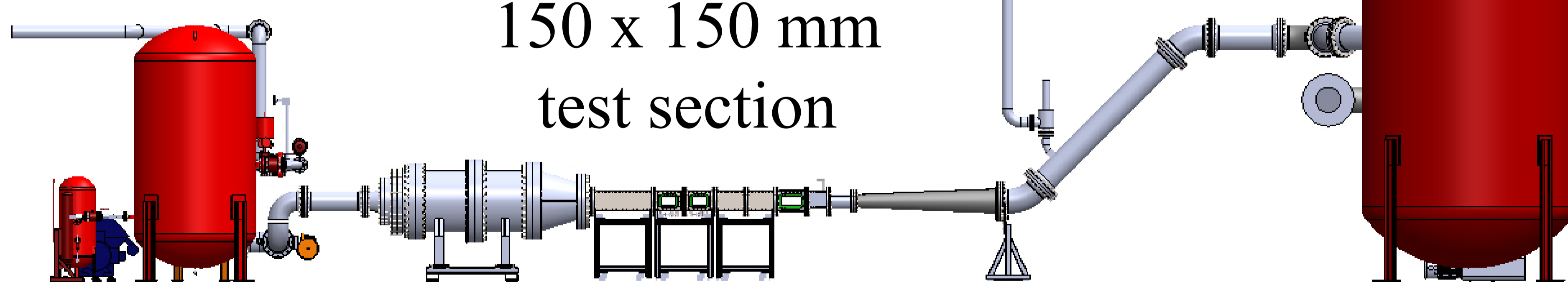

Schematic diagram

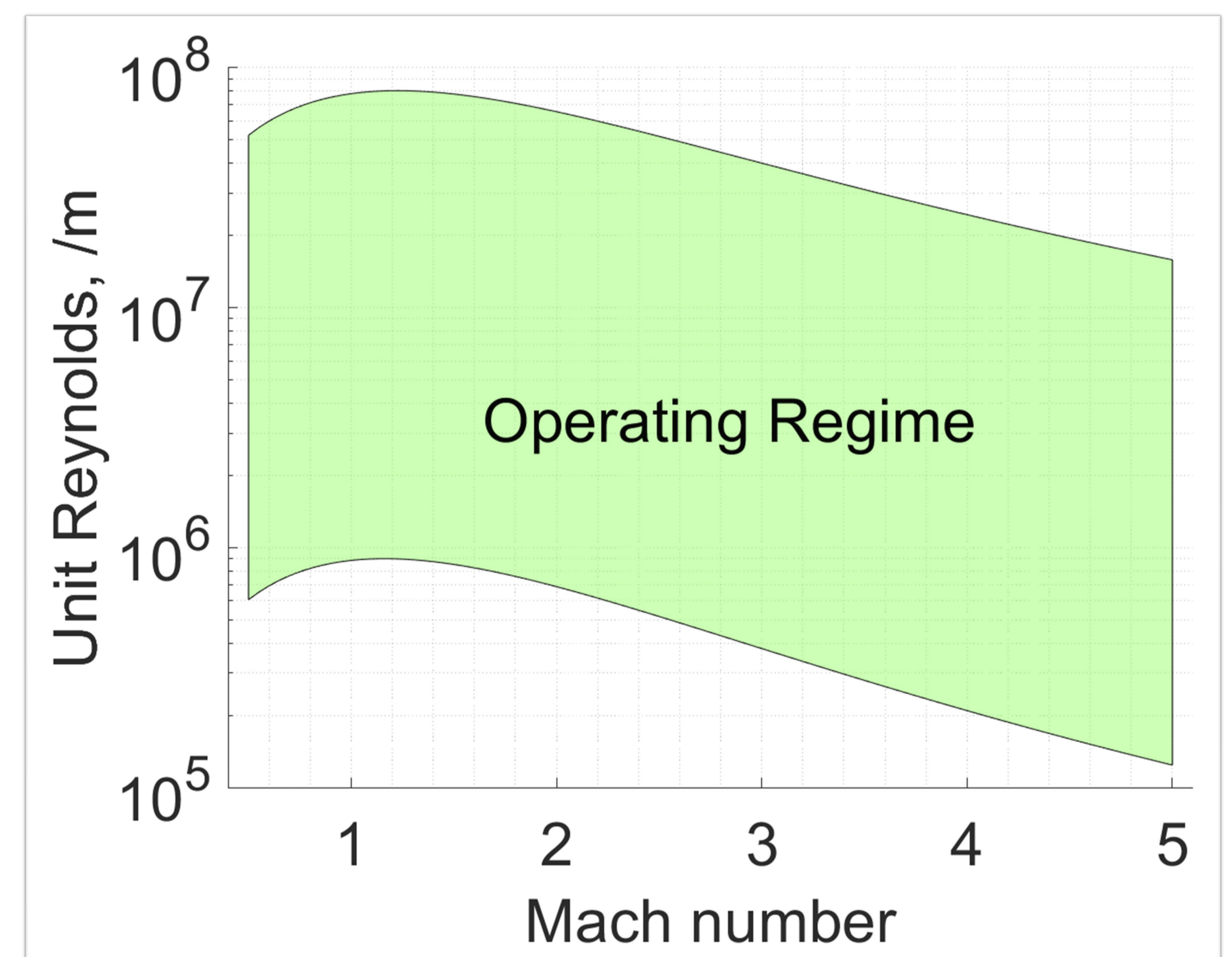

- P_0 : 20 – 500 kPa
- T_0 : 290 – 800 K
- Gas: Air
- Run time: 10 – 30 sec

Measurement techniques

Infrared Thermography

Pressure & Temperature Sensitive Paint

Particle Image Velocimetry

Laser Doppler Anemometry

Schlieren Photography

